

B1161 MALE END VIEW

FEMALE END VIEW

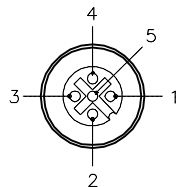
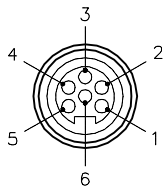

SPECIFICATIONS

CONTACT CARRIER MATERIAL/COLOR	NYLON OR TPU/BLACK
CONTACT MATERIAL/PLATING	BRASS/GOLD
COUPLING NUT MATERIAL/PLATING	BRASS/NICKEL
HOUSING MATERIAL/COLOR	NYLON/YELLOW
O-RING MATERIAL	VITON
RATED CURRENT [A]	4 AMPS PER PORT, 8 AMPS TOTAL
RATED VOLTAGE [V]	10-48 V
TEMPERATURE RANGE	-40°C to +105°C (-40°F to +221°F)
PROTECTION CLASS	MEETS IP67

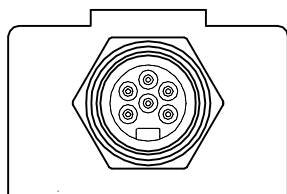
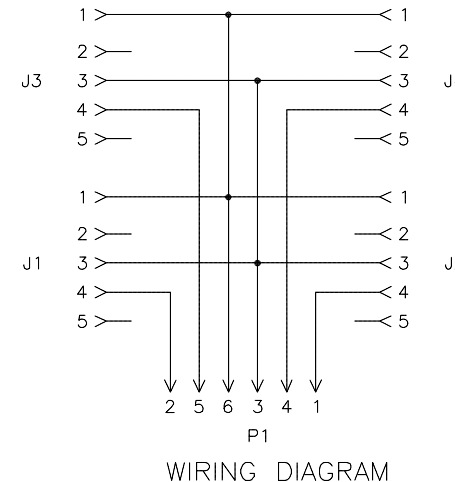
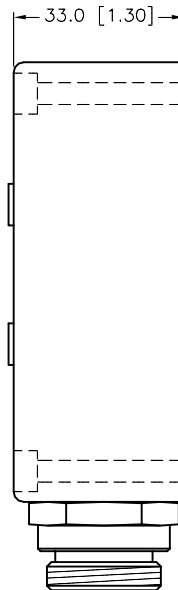
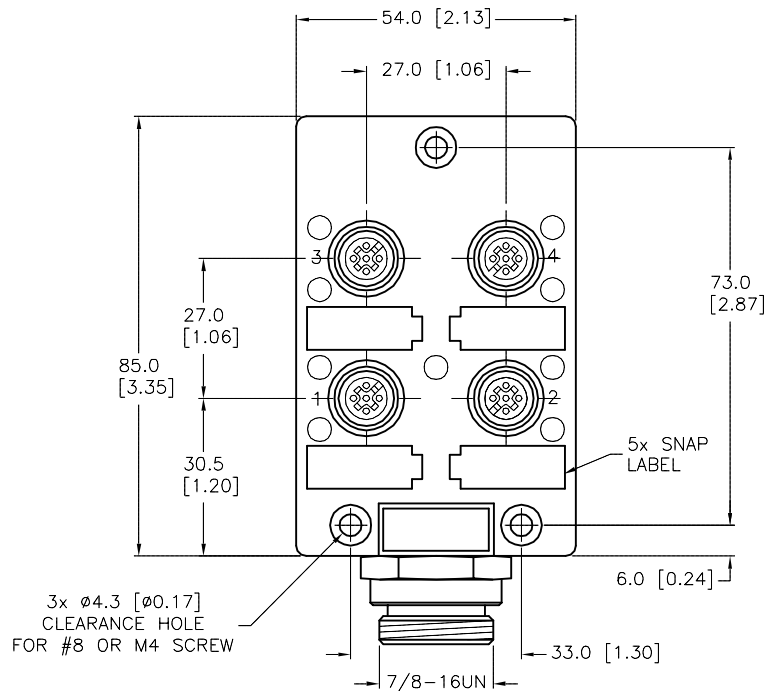

CLOSURE CAPS  
(2x) INCLUDED

SOURCE DRAWING - FOR REFERENCE ONLY

RELATED DOCUMENTS		3RD ANGLE PROJECTION		THIS DRAWING IS CONFIDENTIAL AND THE PROPERTY OF TURCK INC. USE OF THIS DOCUMENT WITHOUT WRITTEN PERMISSION IS PROHIBITED.		3000 CAMPUS DRIVE MINNEAPOLIS, MN 55441 1-800-544-7769 (763) 553-7300 (763) 553-0708 fax turck.com	
1.			DRFT	RWC	DATE	08/11/08	DESCRIPTION VB 40-B1161
2.			APVD		SCALE	1=1.5	
3.		ALL DIMENSIONS DISPLAYED ON THIS DRAWING ARE FOR REFERENCE ONLY	UNIT OF MEASUREMENT		IDENTIFICATION NO.		REV
4.			MILLIMETER [ INCH ]		U7002		D
MATERIAL		SEE SPECIFICATIONS		CONTACT TURCK FOR MORE INFORMATION		DO NOT SCALE THIS DRAWING	
FINISH		SEE SPECIFICATIONS		FILE: U7002		SHEET 1 OF 1	

D	UPDATED CLOSURE CAPS	TV	09/15/15	48811
REV	DESCRIPTION	BY	DATE	ECO NO.